

## Fast Charge Controller for NiCd/NiMH Batteries

### Description

The fast-charge battery controller circuit, U2402B, uses bipolar technology. The IC enables the designer to create an efficient and economic charge system. The U2402B incorporates intelligent multiple-gradient battery-voltage monitoring and mains phase control for power

management. With automatic top-off charging, the integrated circuit ensures that the charge device stops regular charging, before the critical stage of overcharging is achieved. It has two LED driver indications for charge and temperature status.

### Features

- Multiple gradient monitoring
- Temperature window ( $T_{min}/T_{max}$ )
- Exact battery voltage measurement without charge
- Phase control for charge-current regulation
- Top-off and trickle charge function
- Two LED outputs for charge status indication
- Disabling of  $d^2V/dt^2$  switch-off criteria during battery formation
- Battery-voltage check

### Applications

- Portable power tools
- Laptop/notebook personal computer
- Cellular/cordless phones
- Emergency lighting systems
- Hobby equipment
- Camcorder

**Package:** DIP18, SO20

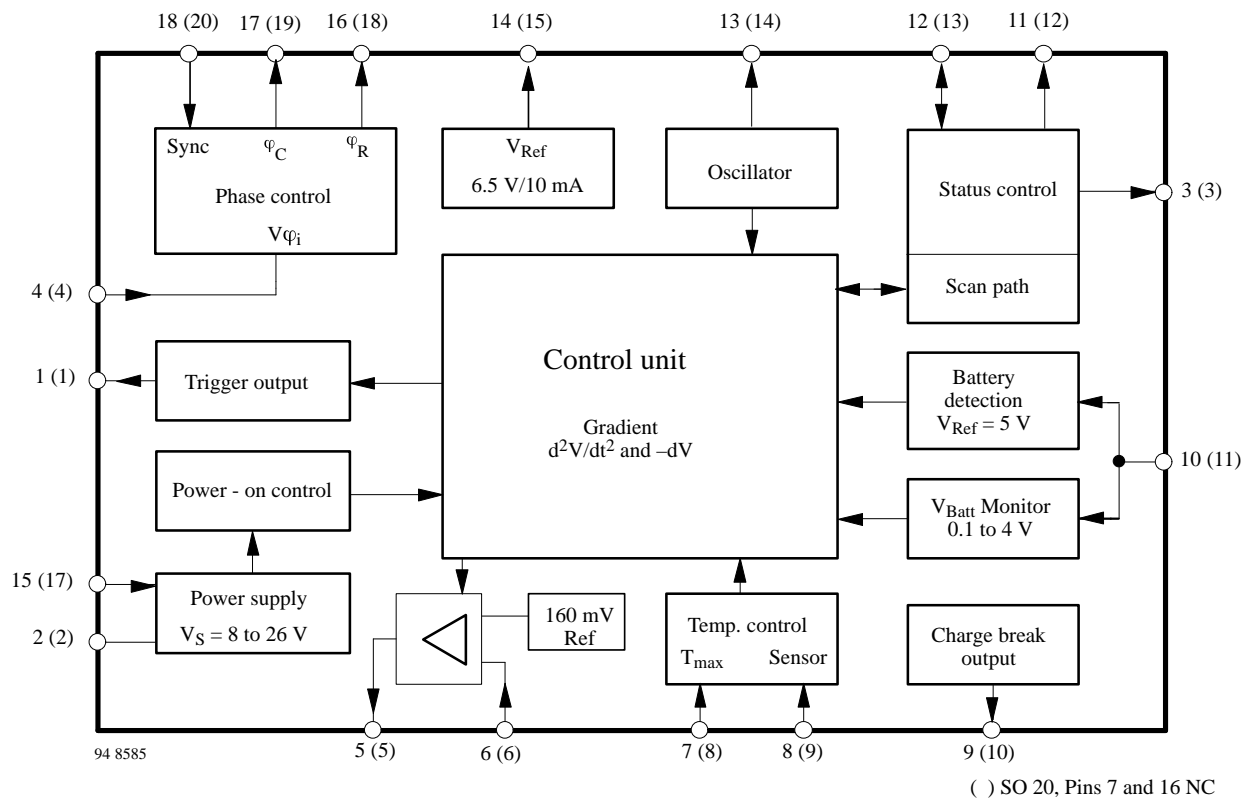
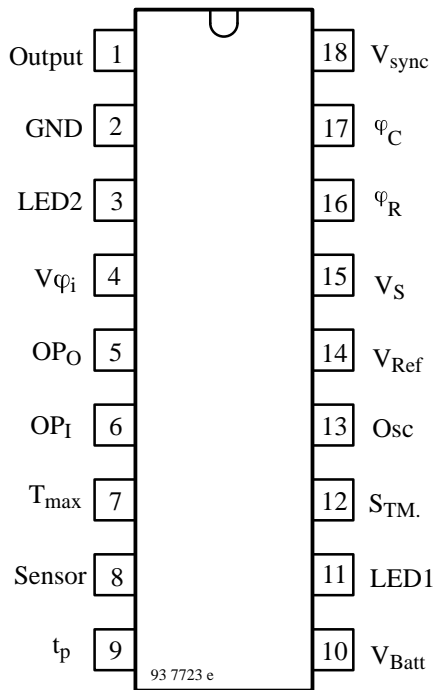

Figure 1. Block diagram

## Pinning

Package: DIP18



## Pin Description

Pin	Symbol	Function
1	Output	Trigger output
2	GND	Ground
3	LED2	Display output "Green"
4	$V\varphi_i$	Phase angle control input voltage
5	$OP_O$	Operational amplifier output
6	$OP_I$	Operational amplifier input
7	$T_{max}$	Maximum temperature
8	Sensor	Temperature sensor
9	$t_p$	Charge break output
10	$V_{Batt}$	Battery voltage
11	LED1	LED display output "Red"
12	$S_{TM.}$	Test mode switch (status control)
13	Osc	Oscillator
14	$V_{Ref}$	Reference output voltage
15	$V_S$	Supply voltage
16	$\varphi_R$	Ramp current adjustment – resistance
17	$\varphi_C$	Ramp voltage – capacitance
18	$V_{sync.}$	Mains synchronization input

Package: SO20

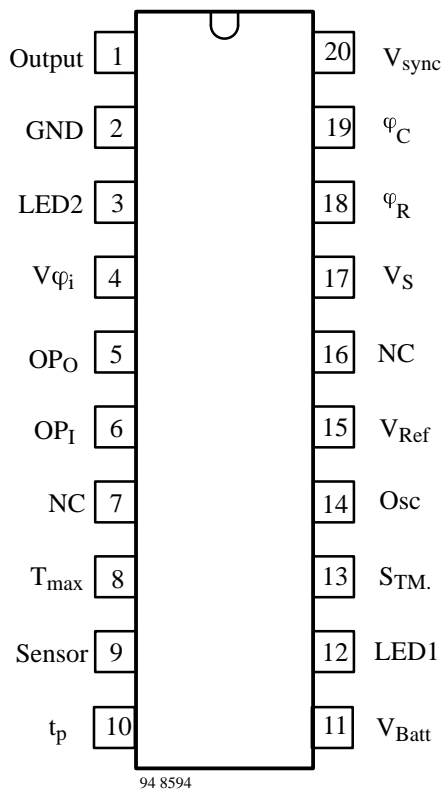

Pin	Symbol	Function
1	Output	Trigger output
2	GND	Ground
3	LED2	Display output "Green"
4	$V\varphi_i$	Phase angle control input voltage
5	$OP_O$	Operational amplifier output
6	$OP_I$	Operational amplifier input
7	NC	Not connected
8	$T_{max}$	Maximum temperature
9	Sensor	Temperature sensor
10	$t_p$	Charge break output
11	$V_{Batt}$	Battery voltage
12	LED1	LED display output "Red"
13	$S_{TM.}$	Test mode switch (status control)
14	Osc	Oscillator
15	$V_{Ref}$	Reference output voltage
16	NC	Not connected
17	$V_S$	Supply voltage
18	$\varphi_R$	Ramp current adjustment – resistance
19	$\varphi_C$	Ramp voltage – capacitance
20	$V_{sync.}$	Mains synchronization input

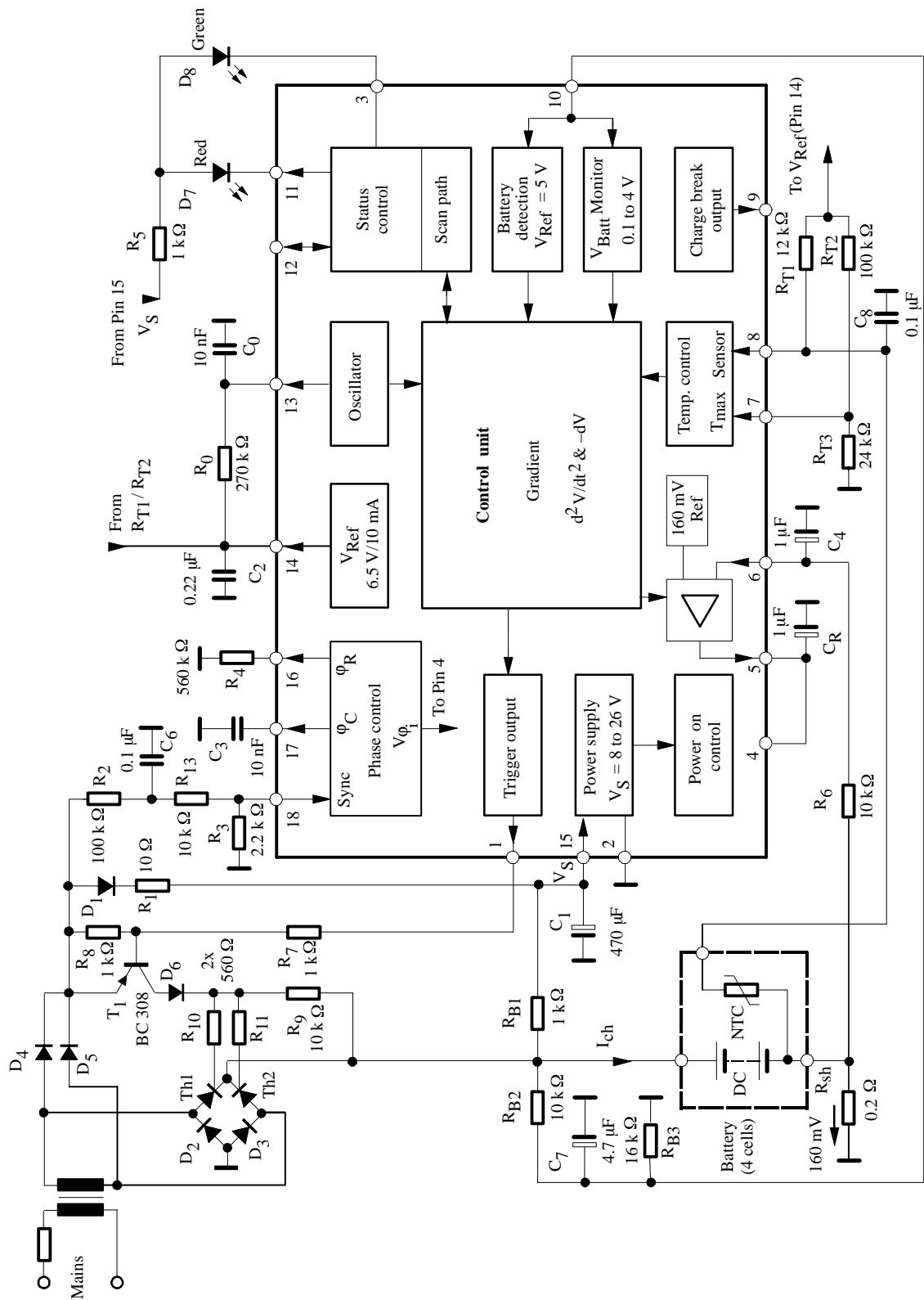

Figure 2. Block diagram with external circuit (DIP pinning)

## General Description

The integrated circuit, U2402B, is designed for charging Nickel-Cadmium (NiCd) and Nickel-Metal-Hydrate (NiMH) batteries. Fast charging results in voltage lobes when fully charged (figure 3). It supplies two identifications (i.e.,  $+ \frac{d^2V}{dt^2}$ , and  $-\Delta V$ ) to end the charge operation at the proper time.

As compared to the existing charge concepts where the charge is terminated – after voltage lobes – according to  $-\Delta V$  and temperature gradient identification, the U2402B-C takes into consideration the additional changes in positive charge curves, according to the second derivative of the voltage with respect to time ( $\frac{d^2V}{dt^2}$ ). The charge identification is the sure method of switching off the fast charge before overcharging the battery. This helps to give the battery a long life by hindering any marked increase in cell pressure and temperature.

Even in critical charge applications, such as a reduced

charge current or with NiMH batteries where weaker charge characteristics are present multiple gradient control results in very efficient switch-off.

An additional temperature control input increases not only the performances of the charge switching characteristics but also prevents the general charging of a battery whose temperature is outside the specified window.

A constant charge current is necessary for continued charge-voltage characteristic. This constant current regulation is achieved with the help of internal amplifier phase control and a simple shunt-current control technique.

All functions relating to battery management can be achieved with DC-supply charge systems. A DC-DC-converter or linear regulator should take over the function of power supply. For further information please refer to the applications.

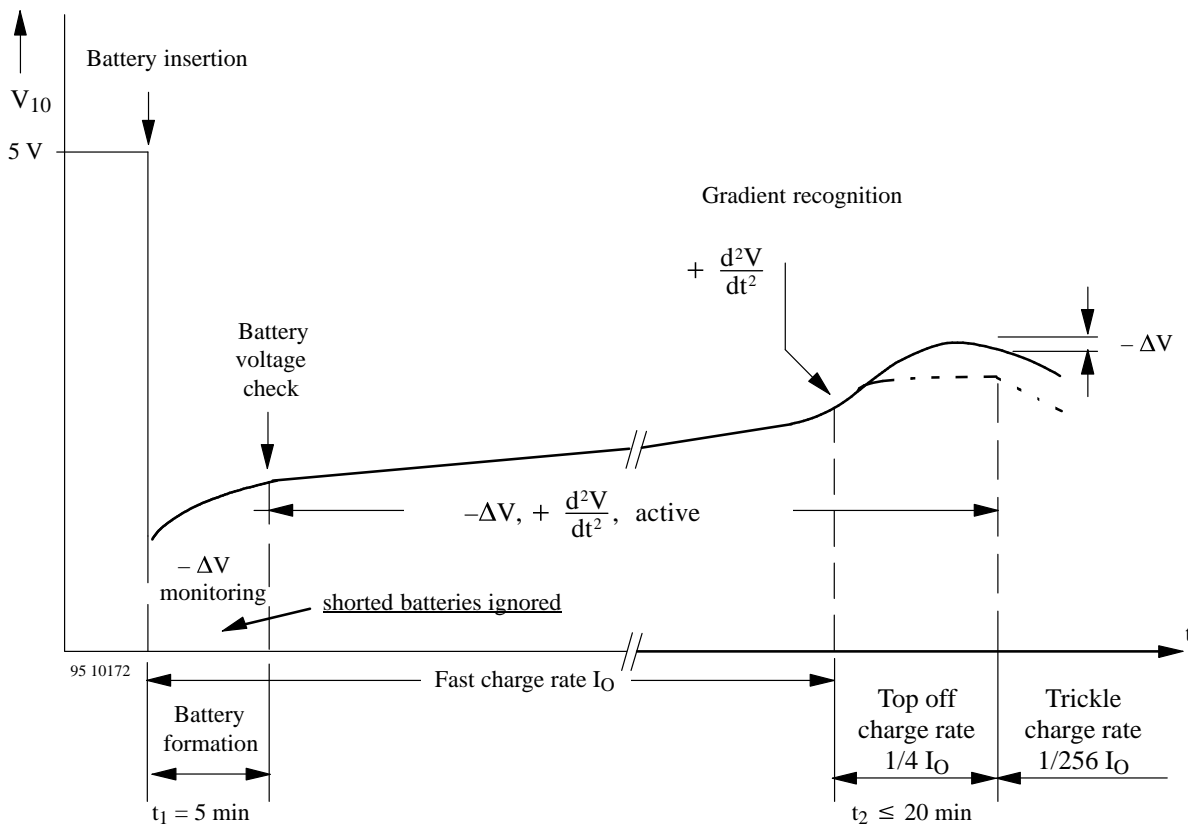

Figure 3. Charge function diagram,  $f_{osc} = 800 \text{ Hz}$

## Flow Chart Explanation, $f_{OSC} = 800$ Hz (Figures 2, 3 and 4)

Battery pack insertion disables the voltage lock at battery detection input Pin 10. All functions in the integrated circuit are reset. For further description, DIP-pinning is taken into consideration.

## Battery Insertion and $-dV$ Monitoring

The charging procedure will be carried out if battery insertion is recognised. If the polarity of the inserted battery is not according to the specification, the fast charge rate will stop immediately. After the polarity test, if positive, the defined fast charge rate,  $I_O$ , begins for the first 5 minutes according to  $-dV$  monitoring. After 5 minutes of charging, the first identification control is executed.

If the inserted battery has a signal across its terminal of less than 0.1 V, then the charging procedure is interrupted. This means that the battery is defective i.e., it is not a rechargeable battery – “shorted batteries ignored”.

Voltage and temperature measurements across the battery are carried out during charge break interval (see figure 6), i.e., currentless or idle measurements.

If the inserted battery is *fully charged*, the  $-dV$  control will signal a charge stop after six measurements (approximately 110 seconds). All the above mentioned functions are recognised during the first 5 minutes according to  $-dV$  method. During this time,  $+d^2V/dt^2$  remains inactive. In this way the battery is protected from unnecessary damage.

## $d^2V/dt^2$ -Gradient

If there is no charge stop within the first 5 minutes after battery insertion, then  $d^2V/dt^2$  monitoring will be active. In this actual charge stage, all stop-charge criteria are active.

When close to the battery’s capacity limit, the battery voltage curve will typically rise. As long as the  $+d^2V/dt^2$  stop-charging criteria are met, the device will stop the fast charge activities.

## Top-Off Charge Stage

By charge disconnection through the  $+d^2V/dt^2$  mode, the device switches automatically to a defined protective top-off charge with a pulse rate of  $1/4 I_O$  (pulse time,  $t_p = 5.12$  s, period,  $T = 20.48$  s).

The top-off charge time is specified for a time of 20 minutes @ 800 Hz.

## Trickle Charge Stage

When top-off charge is terminated, the device switches automatically to trickle charge with  $1/256 I_O$  ( $t_p = 5.12$  s, period = 1310.72 s). The trickle continues until the battery pack is removed.

## Basic Description

### Power Supply, Figure 2

The charge controller allows the direct power supply of 8 to 26 V at Pin 15. Internal regulation limits higher input voltages. Series resistance,  $R_1$ , regulates the supply current,  $I_S$ , to a maximum value of 25 mA. Series resistance is recommended to suppress the noise signal, even below 26 V limitation. It is calculated as follows:

$$R_{1min} \geq \frac{V_{max} - 26 \text{ V}}{25 \text{ mA}}$$

$$R_{1max} \leq \frac{V_{min} - 8 \text{ V}}{I_{tot}}$$

where

$$I_{tot} = I_S + I_{RB1} + I_1$$

$$V_{max}, V_{min} = \text{Rectified voltage}$$

$$I_S = \text{Current consumption (IC) without load}$$

$$I_{RB1} = \text{Current through resistance, } R_{B1}$$

$$I_1 = \text{Trigger current at Pin 1}$$

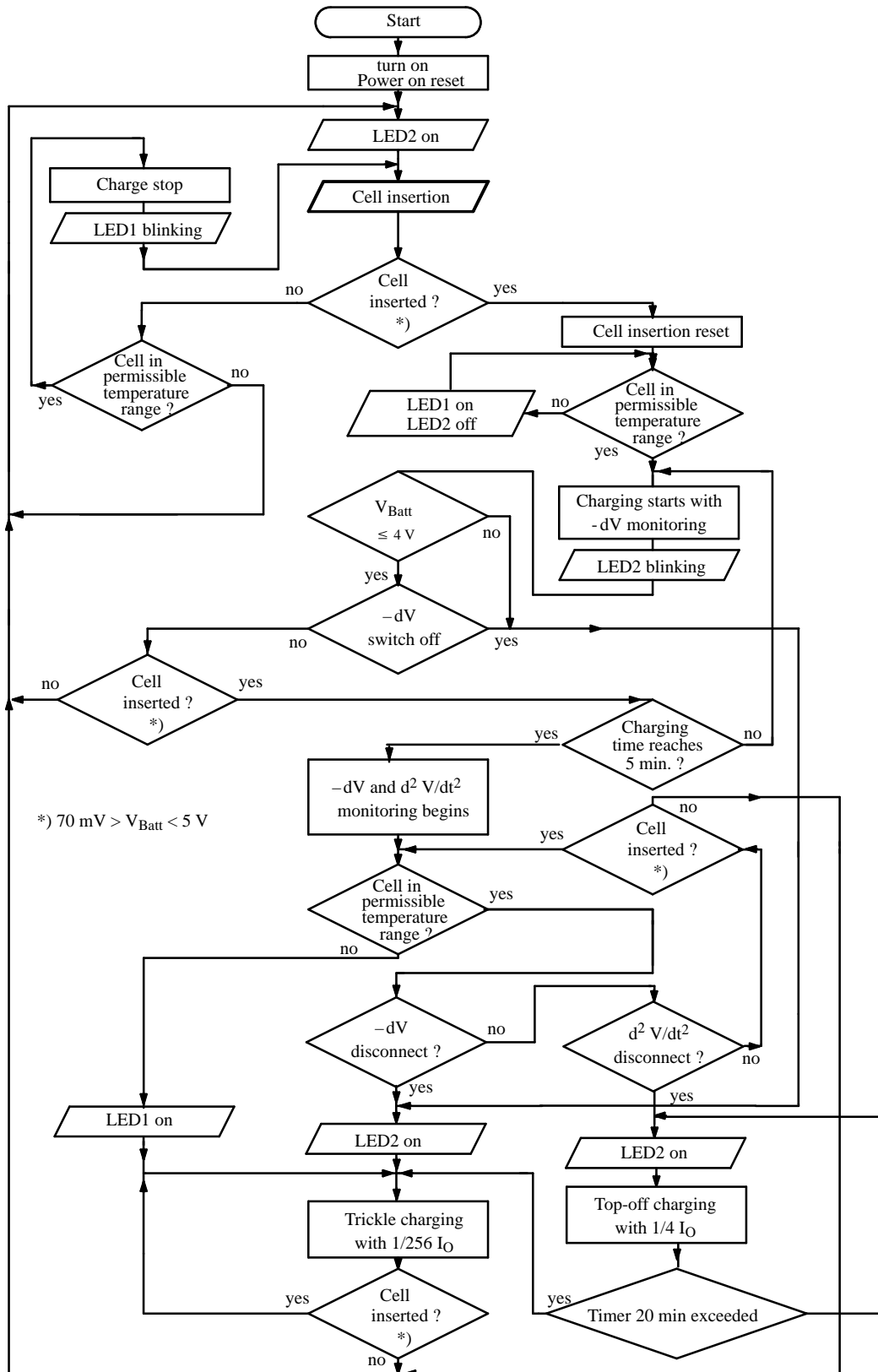

93 7696 e

Figure 4. Flow chart

## Battery Voltage Measurement

The battery voltage measurement at Pin 10 (ADC-converter) has a range of 0 V to 4 V, which means a battery pack containing two cells can be connected without a voltage divider.

If the AD converter is overloaded ( $V_{Batt} \geq 4$  V) a safety switch off occurs. The fast charge cycle is terminated by automatically changing to the trickle charge.

Precaution should be taken that under specified charge current conditions, the final voltage at the input of the converter, Pin 10, should not exceed the threshold voltage level of the reset comparator, which is 5 V. When the battery is removed, the input (Pin 10) is terminated across the pulled-up resistance,  $R_{B1}$ , to the value of 5 V-reset-threshold. In this way, the start of a new charge sequence is guaranteed when a battery is reinserted.

If the battery voltage exceeds the converter range of 4 V, adjusting it by the external voltage divider resistance,  $R_{B2}$  and  $R_{B3}$  is recommended.

Value of the resistance,  $R_{B3}$  is calculated by assuming  $R_{B1} = 1$  k $\Omega$ ,  $R_{B2} = 10$  k $\Omega$ , as follows:

$$R_{B3} = R_{B2} \frac{V_{10max}}{V_{Bmax} - V_{10max}}$$

The minimum supply voltage,  $V_{smin}$ , is calculated for reset function after removing the inserted battery according to:

$$V_{smin} = \frac{0.03mA \cdot R_{B3}(R_{B1} + R_{B2}) + 5V (R_{B1} + R_{B2} + R_{B3})}{R_{B3}}$$

where:

$V_{10max}$  = Max voltage at Pin 10

$V_{Smin}$  = Min supply voltage at the IC (Pin 15)

$V_{Bmax}$  = Max battery voltage

The voltage conditions mentioned above are measured during charge current break (switch-off condition).

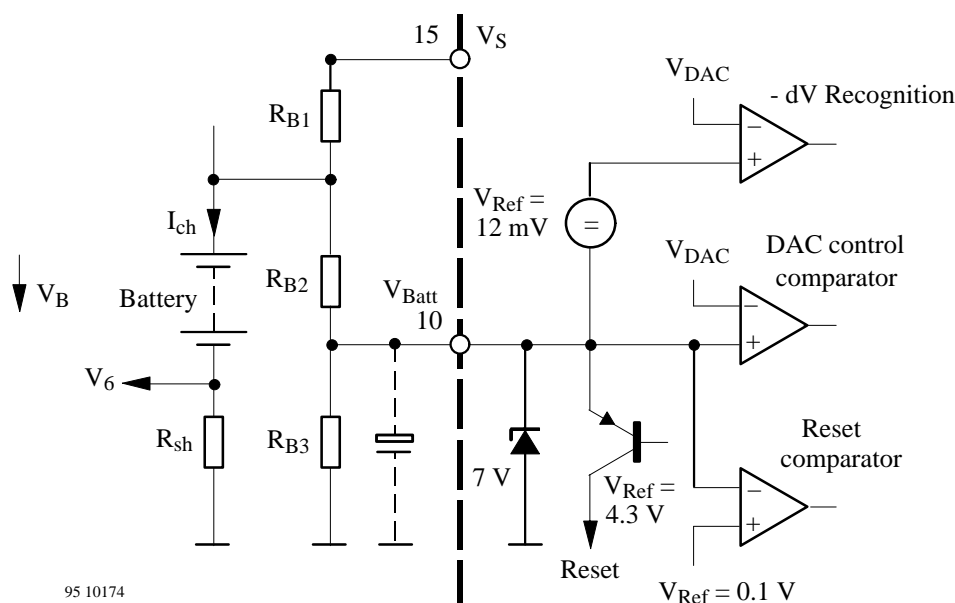

Figure 5. Input configuration for the battery voltage measurement

Table 1. valid when  $V_{10max} = 3.5$  V

Cell No.	1	2	3	4	5	6	7	8	9	10	11	12
$V_{Smin}$ (V)	8	8	8	9	11	13	15	17	19	21	23	25
$R_{B3}$ (k $\Omega$ )	-	-	51	16	10	7.5	5.6	4.7	3.9	3.3	3	2.7

## Analog-Digital-Converter (ADC), Test Sequence

A special analog-digital-converter consists of a five-bit coarse and a five-bit fine converter. It operates by a linear count method which can digitalize a battery voltage of 4 V at Pin 10 in 6.5 mV steps of sensitivity.

In a duty cycle, T, of 20.48 s, the converter executes the measurement from a standard oscillation frequency of  $f_{osc} = 800$  Hz. The voltage measurement is during the charge break time of 2.56 s (see figure 6), i.e., no-load voltage (or currentless phase). Therefore it has optimum measurement accuracy because all interferences are cut-off during this period (e.g., terminal resistances or dynamic load current fluctuations).

After a delay of 1.28 s the actual measurement phase of 1.28 s follows. During this idle interval of cut-off conditions, battery voltage is stabilized and hence measurement is possible.

An output pulse of 10 ms appears at Pin 9 during charge break after a delay of 40 ms. The output signal can be used in a variety of way, e.g., synchronising the test control (reference measurement).

## Plausibility for Charge Break

There are two criterian considered for charge break plausibility:

### – $\Delta V$ Cut-Off

When the signal at Pin 10 of the DA converter is 12 mV below the actual value, the comparator identifies it as a voltage drop of  $-dV$ . The validity of  $-dV$  cut-off is considered only if the actual value is below 12 mV for three consecutive cycles of measurement.

### $d^2V/dt^2$ Cut-Off

A four bit forward/ backward counter is used to register the slope change ( $d^2V/dt^2$ ,  $V_{Batt} - \text{slope}$ ). This counter is clocked by each tracking phase of the fine AD-counter. Beginning from its initial value, the counter counts the first eight cycles in forward direction and the next eight cycles in reverse direction. At the end of 16 cycles, the actual value is compared with the initial value. If there is a difference of more than two LSB-bit (13.5 mV) from the actual counter value, then there is an identification of slope change which leads to normal charge cut-off. A second counter in the same configuration is operating in parallel with eight clock cycles delay, to reduce the total cut-off delay, from 16 test cycles to eight test cycles.

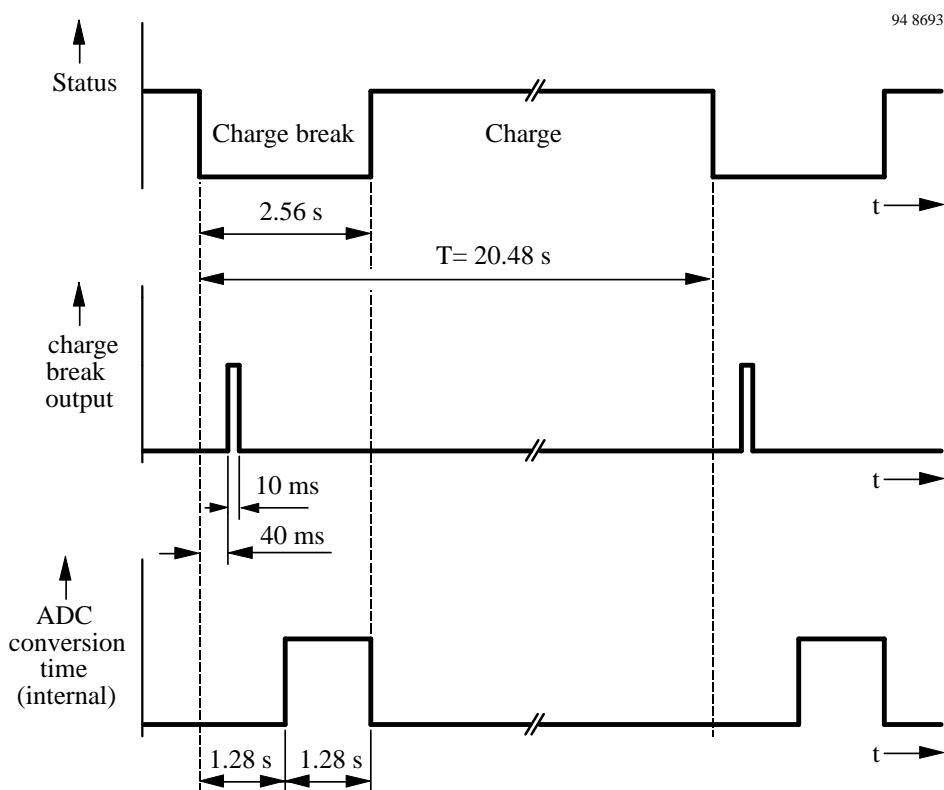

Figure 6. Operating sequence of voltage measurements



**Temperature Control, Figure 7**

When the battery temperature is not inside the specified *temperature windows*, the overall temperature control will not allow the charge process. Sensor short circuit or interruption also leads to switch-off.

Differentiation is made whether the battery exceeds the maximum allowable temperature,  $T_{max}$ , during the charge phase or the battery temperature is outside the temperature window range before battery connection.

A permanent switch-off follows after a measurement period of 20.48 s, if the temperature exceeds a specified level, which is denoted by a status of a red LED<sub>1</sub>. A charge sequence will start only when the specified window temperature range is attained. In such a case, the green LED<sub>2</sub> starts blinking immediately showing a quasi *charge readiness*, even though there is no charge current flow.

The temperature window is specified between two voltage transitions. The upper voltage transition is

specified by the internal reference voltage of 4 V, and the lower voltage transition is represented by the external voltage divider resistances  $R_{T2}$  and  $R_{T3}$ .

NTC sensors are normally used to control the temperature of the battery pack. If the resistance values of NTC are known for maximum and minimum conditions of allowable temperature, then other resistance values,  $R_{T1}$ ,  $R_{T2}$  and  $R_{T3}$  are calculated as follows:

suppose  $R_{T2} = 100\text{ k}\Omega$ , then

$$R_{T1} = R_{NTCmax} \frac{V_{Ref} - 4V}{4V}$$

$$R_{T3} = R_{NTCmin} \frac{R_{T2}}{R_{T1}}$$

If NTC sensors are not used, then select the circuit configuration according to figure 10.

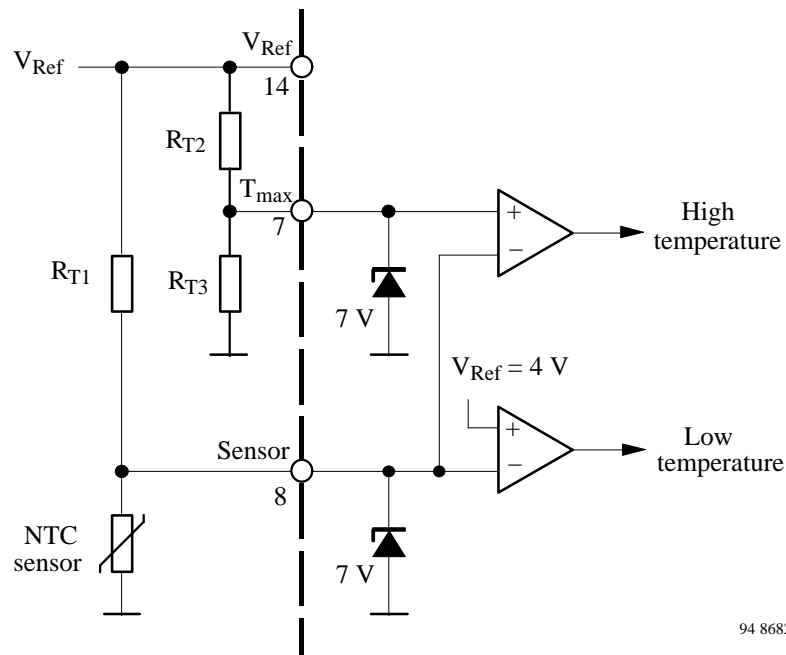

Figure 7. Temperature window

94 8682

## Current Regulation Via Phase Control (Figure 8)

### Phase Control

An internal phase control monitors the angle of current flow through the external thyristors as shown in figure 2. The phase control block represents a ramp generator synchronized by mains zero cross over and a comparator.

The comparator will isolate the trigger output, Pin 1, until the end of the half wave (figure 8) when the ramp voltage,  $V_{ramp}$ , reaches the control voltage level,  $V_{\phi i}$ , within a mains half wave.

### Charge Current Regulation (Figure 2)

According to figure 2 the operational amplifier (OpAmp) regulates the charge current,  $I_{ch} (= 160 \text{ mV} / R_{sh})$ , average value. The OpAmp detects the voltage drop across the shunt resistor ( $R_{sh}$ ) at input Pin 6 as an actual value. The actual value will then be compared with an internal reference value (rated value of 160 mV).

The regulator's output signal,  $V_5$ , is at the same time the control signal of the phase control,  $V_{\phi i}$  (Pin 4). In the adjusted state, the OpAmp regulates the current flow angle through the phase control until the average value at the shunt resistor reaches the rated value of 160 mV.

The corresponding evaluation of capacitor  $C_R$  at the operational amplifier (regulator) output determines the dynamic performance of current regulation.

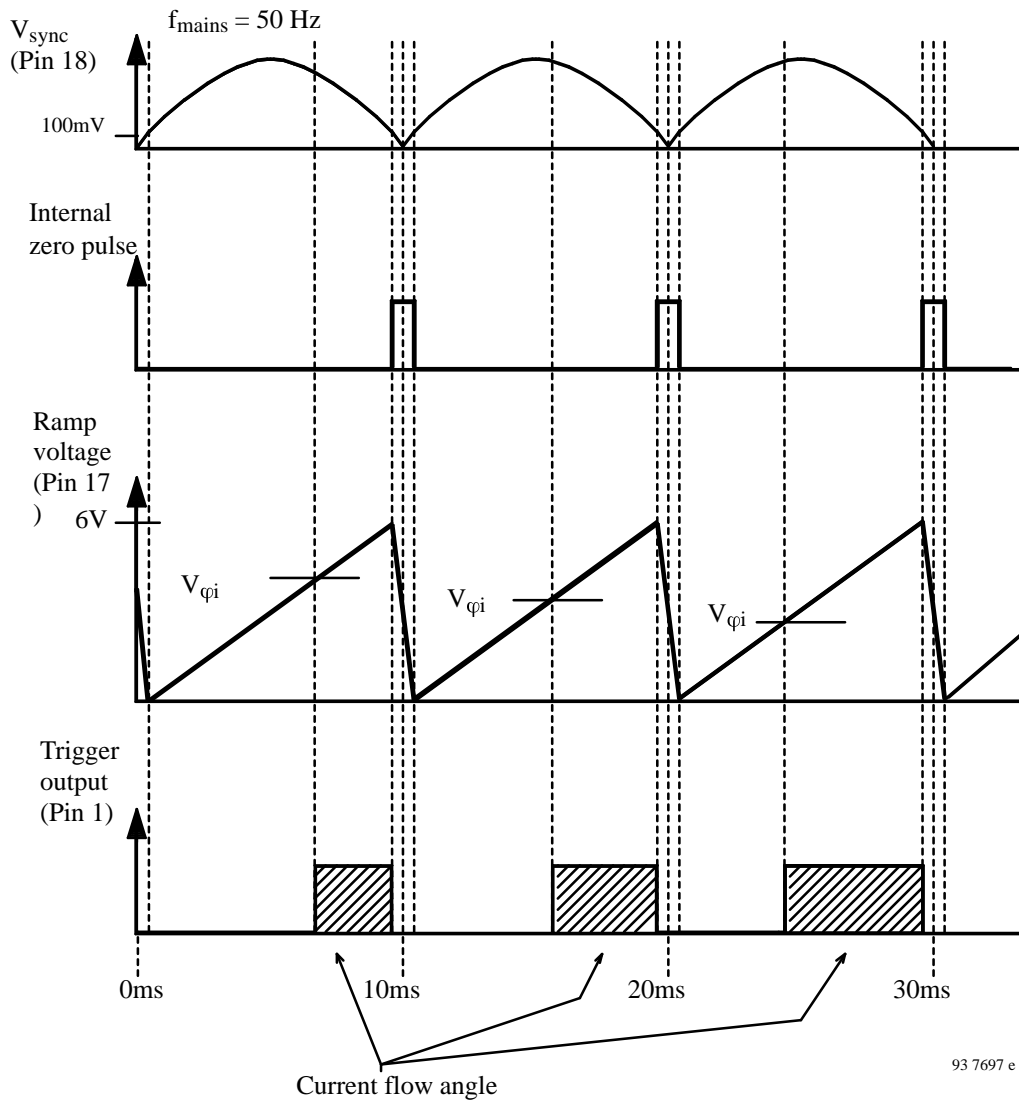

Figure 8. Phase control function diagram

**Status Control**

Status control inside and outside the charging process are designated by LED<sub>1</sub> and LED<sub>2</sub> outputs given in the table below:

LED1 (red)	LED2 (green)	Status
OFF	ON	No battery, top off charge, trickle charge
OFF	Blinking	Quick charge, temperature out of the window before battery insertion or power on
ON	OFF	Temperature out of the window
Blinking	OFF	Battery break (interrupt) or short circuit

The blink frequency of LED outputs can be calculated as follows:

$$f_{(LED)} = \frac{\text{Oscillator frequency, } f_{osc}}{1024}$$

**Oscillator**

Time sequences regarding measured values and evaluation are determined by the system oscillator. All the technical data given in the description are with the standard frequency 800 Hz.

It is possible to alter the frequency range in a certain limitation. Figure 9 shows the frequency versus resistance curves with different capacitance values.

**Oscillation Frequency Adjustment**

Recommendations:

0.5C charge	$0.5 \times 500 \text{ Hz} =$	250 Hz
1C charge		500 Hz
2C charge	$2 \times 500 \text{ Hz} =$	1000 Hz
3C charge	$3 \times 500 \text{ Hz} =$	1500 Hz

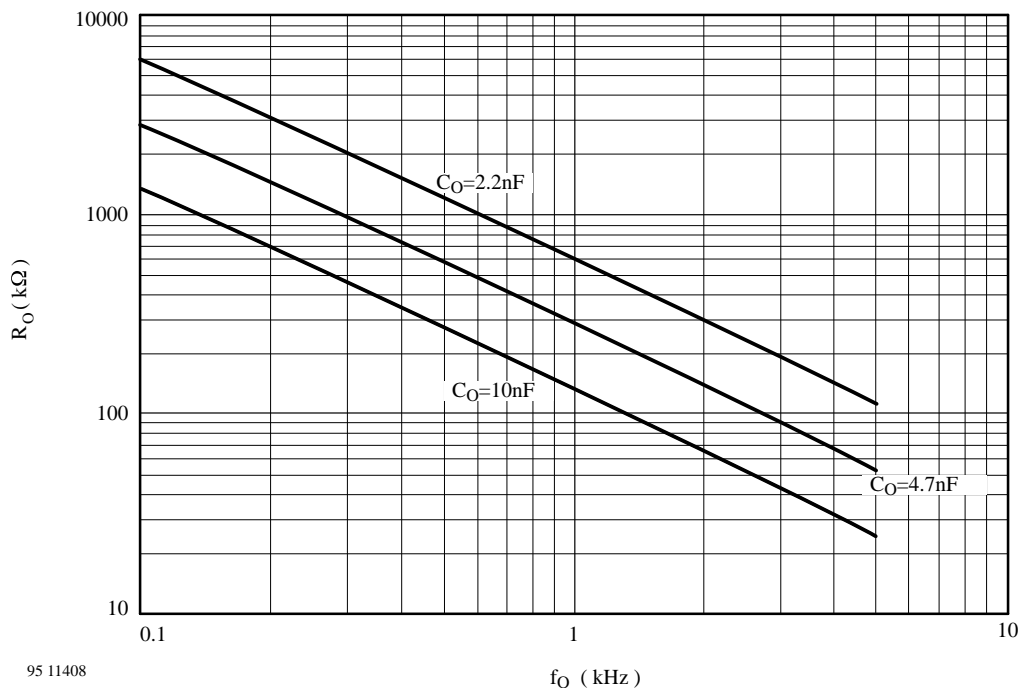

Figure 9. Frequency versus resistance for different capacitance values

## Absolute Maximum Ratings

Reference point Pin 2 (GND), unless otherwise specified

Parameters	Symbol	Value	Unit
Supply voltage	$V_S$	26	V
Voltage limitation	$I_S = 10 \text{ mA}$	31	
Current limitation	$I_S$	25 100	mA
Voltages at different pins	V	26 7	V
Currents at different pins	I	25 10	mA
Power dissipation	$P_{tot}$	650	mW
Ambient temperature range	$T_{amb}$	-10 to +85	°C
Junction temperature	$T_j$	125	°C
Storage temperature range	$T_{stg}$	-40 to +125	°C

## Thermal Resistance

Parameters	Symbol	Value	Unit
Junction ambient	$R_{thJA}$	80	K/W
	$R_{thJA}$	100	K/W

## Electrical Characteristics

$V_S = 12 \text{ V}$ ,  $T_{amb} = 25^\circ\text{C}$ , reference point Pin 2 (GND), unless otherwise specified.

Parameters	Test Conditions / Pins	Symbol	Min.	Typ.	Max.	Unit
<b>Power supply</b>						
Pin 15						
Voltage range		$V_S$	8		26	V
Power-on threshold	ON	$V_S$	3.0		3.8	V
	OFF		4.7		5.7	V
Current consumption	without load	$I_S$	3.9		9.1	mA
<b>Reference</b>						
Pin 14						
Reference voltage	$I_{Ref} = 5 \text{ mA}$	$V_{Ref}$	6.19	6.5	6.71	V
	$I_{Ref} = 10 \text{ mA}$		6.14	6.5	6.77	V
Reference current		$-I_{Ref}$			10	mA
Temperature coefficient		TC		-0.7		mV/K
<b>Operational amplifier OP</b>						
Output voltage range	$I_5 = 0$ Pin 5	$V_5$	0.15		5.8	V
Output current range	$V_5 = 3.25 \text{ V}$ Pin 5	$\pm I_5$	80			$\mu\text{A}$
Output pause current	Pin 5	$-I_{pause}$	100			$\mu\text{A}$
Non-inverting input voltage	Pin 6	$V_6$	0		5	V
Non-inverting input current	Pin 6	$\pm I_6$			0.5	$\mu\text{A}$

Parameters	Test Conditions / Pins	Symbol	Min.	Typ.	Max.	Unit
<b>Comparator or temperature control</b>						
Input current	Pins 7 and 8	$I_{7,8}$	-0.5		0.5	$\mu\text{A}$
Input voltage range	Pins 7 and 8	$V_{7,8}$	0		5	V
Threshold voltage	Pin 8	$V_8$	3.85		4.15	V
<b>Charge break output</b> Pin 9						
Output voltage	High, $I_9 = 4 \text{ mA}$ Low, $I_9 = 0 \text{ mA}$	$V_9$	8.4		100	V mV
Output current	$V_9 = 1 \text{ V}$	$I_9$	10			mA
<b>Battery detection</b> Pin 10						
Analog-digital converter	Conversion range Full scale level	$V_{\text{Batt}}$	0 3.85		4.0	V
Input current	$0.1 \text{ V} \leq V_{\text{Batt}} \leq 4.5 \text{ V}$	$-I_{\text{Batt}}$			0.5	$\mu\text{A}$
Input voltage for reset		$V_{\text{Batt}}$	4.8	5.0	5.3	V
Input current for reset	$V_{\text{Batt}} \geq 5 \text{ V}$	$I_{\text{Batt}}$	8		35	$\mu\text{A}$
Battery detection	Maximum voltage	$\Delta V_{\text{Batt}}$	80		120	mV
Hysteresis	Maximum voltage	$V_{\text{hys}}$		15		mV
<b>Mode select</b> Pin 12						
Threshold voltage	Test mode	$V_{12}$			4.7	V
Input current	Normal mode Open	$I_{12}$	20 0			$\mu\text{A}$
<b>Sync. oscillator</b> Pin 13						
Frequency	$R = 150 \text{ k}\Omega$ $C = 10 \text{ nF}$	$f_{\text{osc}}$		800		Hz
Threshold voltage	High level Low level	$V_{\text{T(H)}}$ $V_{\text{T(L)}}$		$4.3 \pm 3\%$ $2.2 \pm 3\%$		V
Input current		$I_{13}$	-0.5		0.5	$\mu\text{A}$
<b>Phase control</b>						
Ramp voltage	$R_{\varphi} = 270 \text{ k}\Omega$ Pin 16	$V_{16}$	2.9		3.9	V
Ramp current		$I_{16}$	0		100	$\mu\text{A}$
Ramp voltage range		$V_{17}$	0		5	V
Ramp discharge current		$I_{17}$	3.3		8	mA
<b>Synchronization</b> Pin 18						
Minimum current	$V_{\text{sync}} \leq 80 \text{ mV}$	$-I_{\text{sync}}$	10		2	$\mu\text{A}$
Maximum current	$V_{\text{sync}} = 0 \text{ V}$	$-I_{\text{sync}}$	15		30	$\mu\text{A}$
Zero voltage detection		$V_{\text{sync}}$	83	100	135	mV
Hysteresis		$V_{\text{hys}}$		15		mV
<b>Charge stop criteria (function)</b> Pin 10						
Positive gradient-turn-off threshold	$f_{\text{osc}} = 800 \text{ Hz}$	$d^2V/dt^2$		4.8		$\text{mV}/\text{min}^2$
- $\Delta V$ -turn-off threshold		$-\Delta V$		12		mV

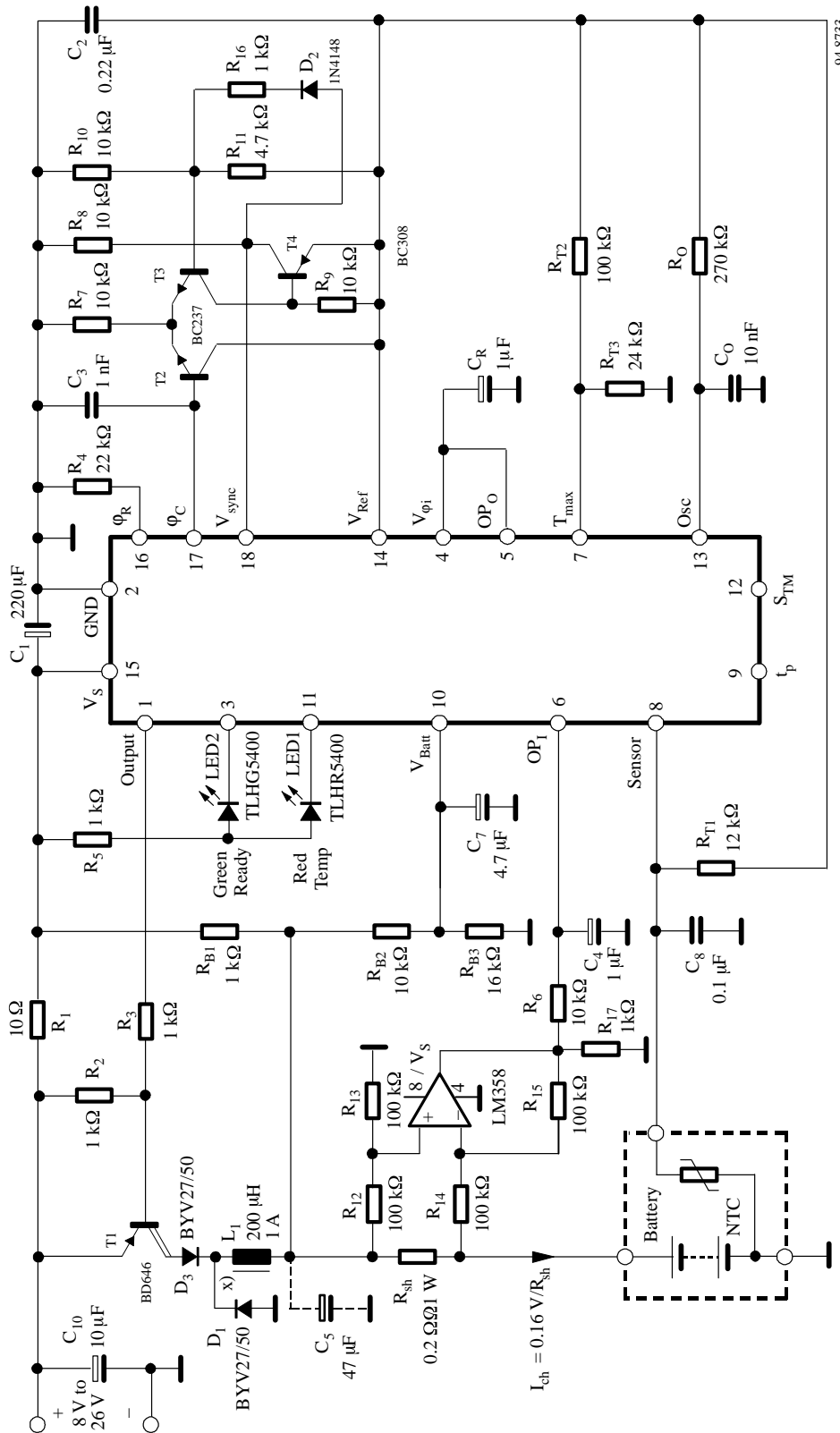

94.8733

x) Manufacturer Pikaatron

Figure 10. Car battery supplied charge system with high side current detection for four NiCd/NiMH cells @ 800 mA

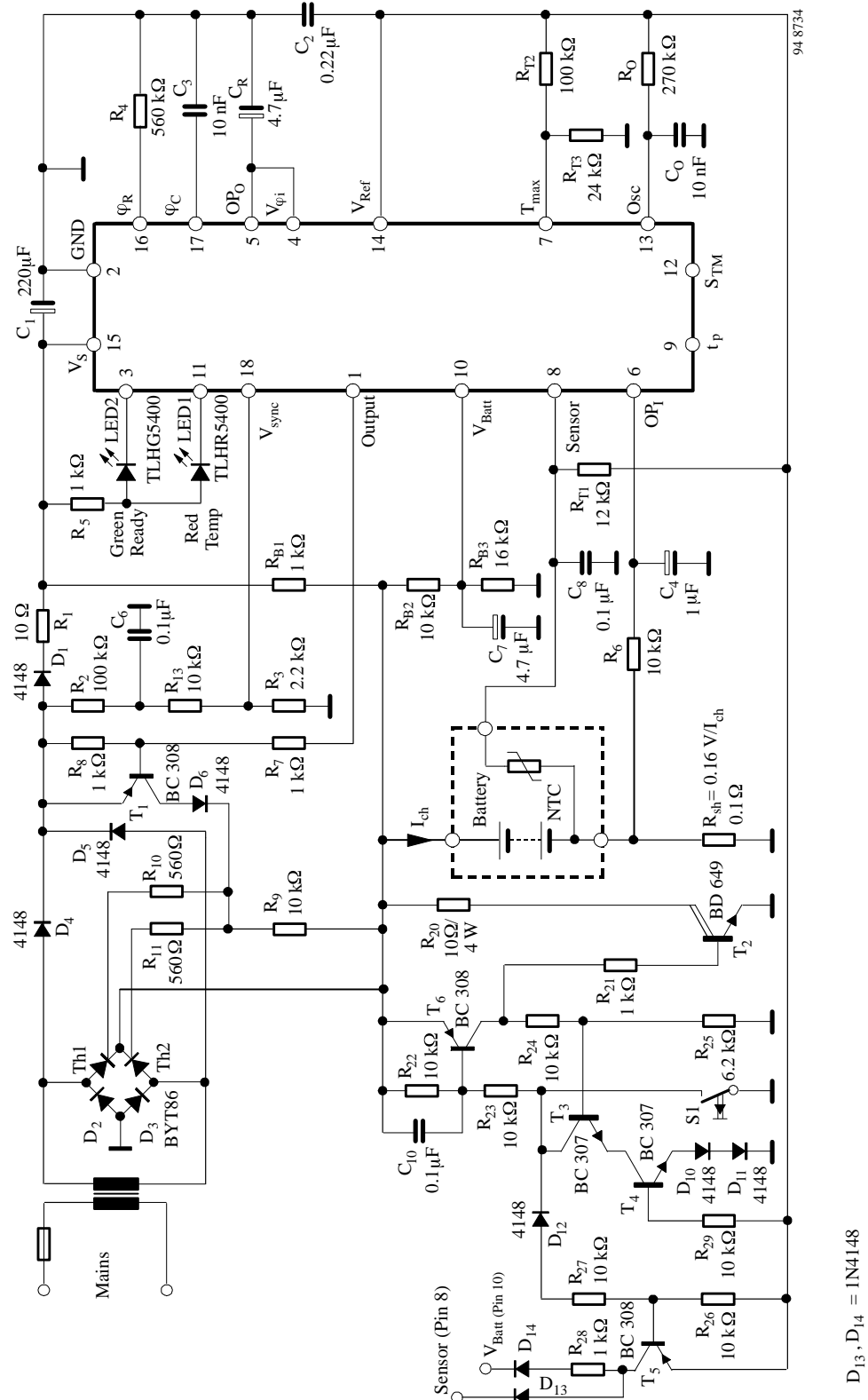
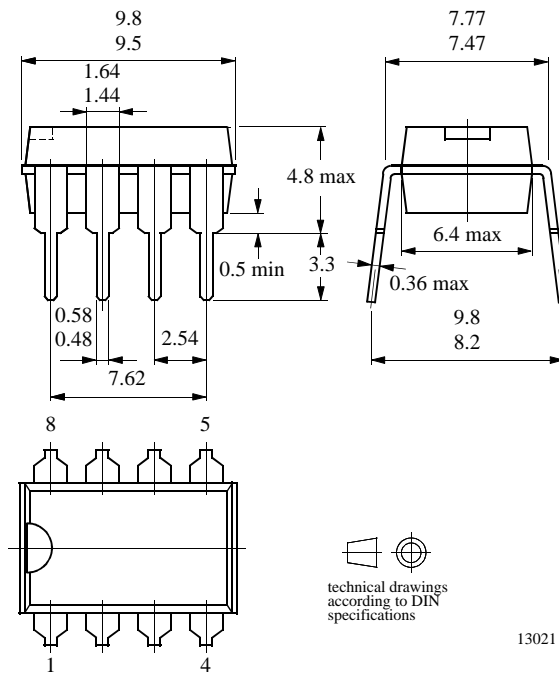

Figure 11. Standard application with predischage for eight NiCd/NiMH cells @ 1600 mA

## Package Information

### Package DIP8

Dimensions in mm



### Package SO20

Dimensions in mm

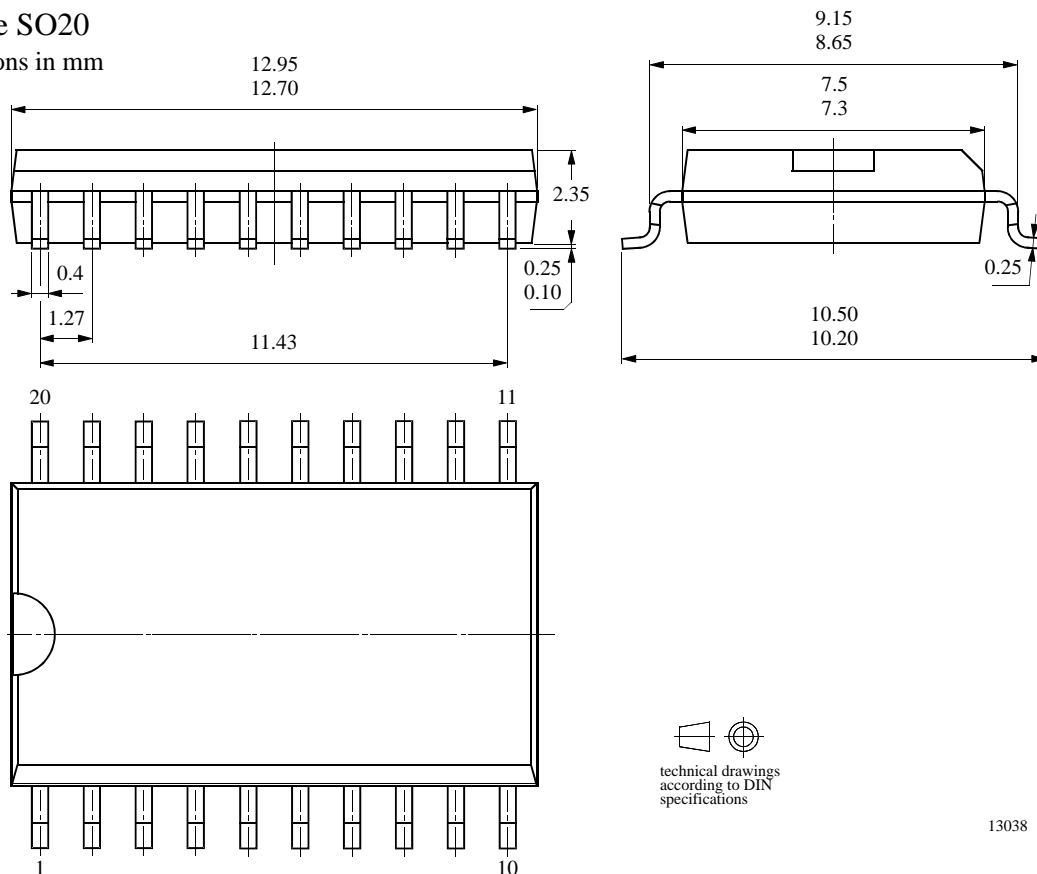



## Ozone Depleting Substances Policy Statement

It is the policy of **TEMIC TELEFUNKEN microelectronic GmbH** to

1. Meet all present and future national and international statutory requirements.
2. Regularly and continuously improve the performance of our products, processes, distribution and operating systems with respect to their impact on the health and safety of our employees and the public, as well as their impact on the environment.

It is particular concern to control or eliminate releases of those substances into the atmosphere which are known as ozone depleting substances (ODSs).

The Montreal Protocol (1987) and its London Amendments (1990) intend to severely restrict the use of ODSs and forbid their use within the next ten years. Various national and international initiatives are pressing for an earlier ban on these substances.

**TEMIC TELEFUNKEN microelectronic GmbH** semiconductor division has been able to use its policy of continuous improvements to eliminate the use of ODSs listed in the following documents.

1. Annex A, B and list of transitional substances of the Montreal Protocol and the London Amendments respectively
2. Class I and II ozone depleting substances in the Clean Air Act Amendments of 1990 by the Environmental Protection Agency (EPA) in the USA
3. Council Decision 88/540/EEC and 91/690/EEC Annex A, B and C (transitional substances) respectively.

**TEMIC** can certify that our semiconductors are not manufactured with ozone depleting substances and do not contain such substances.

**We reserve the right to make changes to improve technical design and may do so without further notice.**

Parameters can vary in different applications. All operating parameters must be validated for each customer application by the customer. Should the buyer use TEMIC products for any unintended or unauthorized application, the buyer shall indemnify TEMIC against all claims, costs, damages, and expenses, arising out of, directly or indirectly, any claim of personal damage, injury or death associated with such unintended or unauthorized use.

TEMIC TELEFUNKEN microelectronic GmbH, P.O.B. 3535, D-74025 Heilbronn, Germany  
Telephone: 49 (0)7131 67 2831, Fax number: 49 (0)7131 67 2423